

MuntsOS Embedded Linux

Application Note #4: Ada LED Flash Example

Revision 6
19 March 2025

by Philip Munts
dba Munts Technologies
<http://tech.munts.com>

Introduction

This application note describes how to create, build, and run an Ada program to flash an LED on a target computer running **MuntsOS Embedded Linux**.

Prerequisites

The **MuntsOS Embedded Linux** software development environment must be installed on a Linux development computer ([AppNote #1](#) or [AppNote #2](#)).

MuntsOS Embedded Linux must be installed on the target computer ([AppNote #3](#)).

Test Platform Hardware

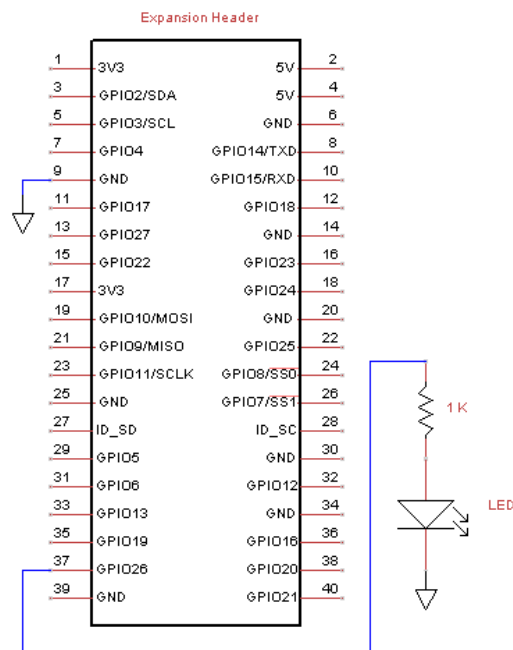
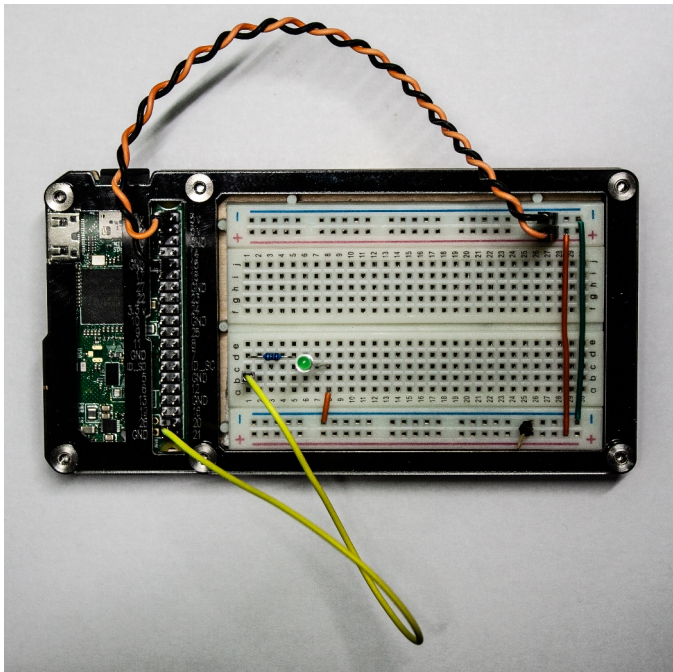

The test platform for the purposes of this application note consists of a [Raspberry Pi Zero 2 Wireless](#) mounted in a [Zebra Zero Plus Breadboard](#) case. The orange and black jumper wires connect +3.3V and GND on the Raspberry Pi expansion header to the breadboard power rails. The yellow jumper connects GPIO26 to a 1K ohm current limiting resistor and an LED.

Test Program Source Code

Available for download at: <https://repo.munts.com/muntsos/doc/blinky/blinky.adb>

```
WITH Ada.Text_IO; USE Ada.Text_IO;

WITH GPIO.libsimpleio;
WITH RaspberryPi;

PROCEDURE blinky IS

    LED : GPIO.Pin;

BEGIN
    New_Line;
    Put_Line("MuntsOS Ada LED Test");
    New_Line;

    -- Configure a GPIO output to drive an LED

    LED := GPIO.libsimpleio.Create(RaspberryPi.GPIO26, GPIO.Output);

    -- Flash the LED forever (until killed)

    Put_Line("Press CONTROL-C to exit");
    New_Line;

    LOOP
        LED.Put(NOT LED.Get);
        DELAY 0.5;
    END LOOP;
END blinky;
```

Exercise

This example exercise demonstrates how to create an Ada program project (outside of the **MuntsOS** code tree checkout), compile it, and run it on the test platform hardware.

Step 1: Prepare the **blinky** project:

```
mkdir $HOME/blinky
cd $HOME/blinky
wget https://repo.munts.com/muntsos/doc/.blinky/Makefile.ada
mv Makefile.ada Makefile
wget https://repo.munts.com/muntsos/doc/.blinky/blinky.adb
```

Step 2: Build the **blinky** project:

```
make BOARDNAME=RaspberryPiZero2W
```

Step 3: Copy **blinky** to the test platform:

```
scp blinky root@snoopy:.
```

Step 4: Run the test program on the test platform:

```
ssh root@snoopy
./blinky
```

The LED should begin flashing once a second, until you press **CONTROL-C**.