

MuntsOS Embedded Linux

Application Note #7: Ada LED Flash Example Using Alire

Revision 8
19 March 2025

by Philip Munts
dba Munts Technologies
<http://tech.munts.com>

Introduction

This application note describes how to create, build, and run an Ada program to flash an LED on a target computer running **MuntsOS Embedded Linux**, using the **Alire** (Ada Library REpository) development environment (<https://alire.ada.dev>).

Prerequisites

The **MuntsOS Embedded Linux** software development environment must be installed on a Linux development computer ([AppNote #1](#) or [AppNote #2](#)).

The `a1r` command line tool for **Alire** must be installed on the desktop Linux system (following the procedure specified at <https://alire.ada.dev/docs/#installation>).

MuntsOS Embedded Linux must be installed on the target computer ([AppNote #3](#)).

Target Platform Hardware

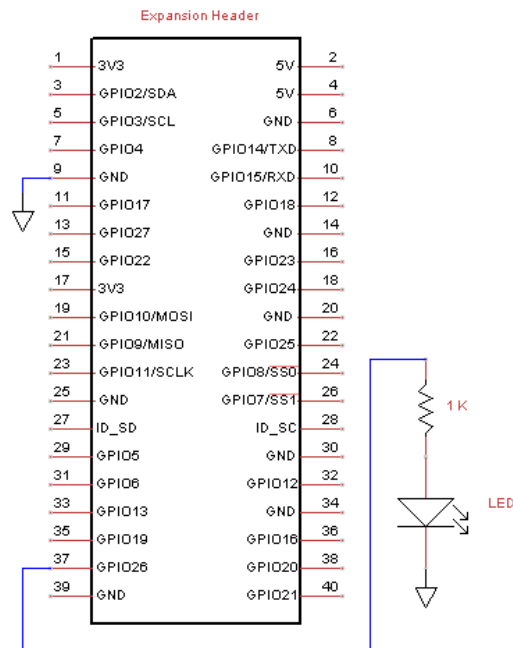
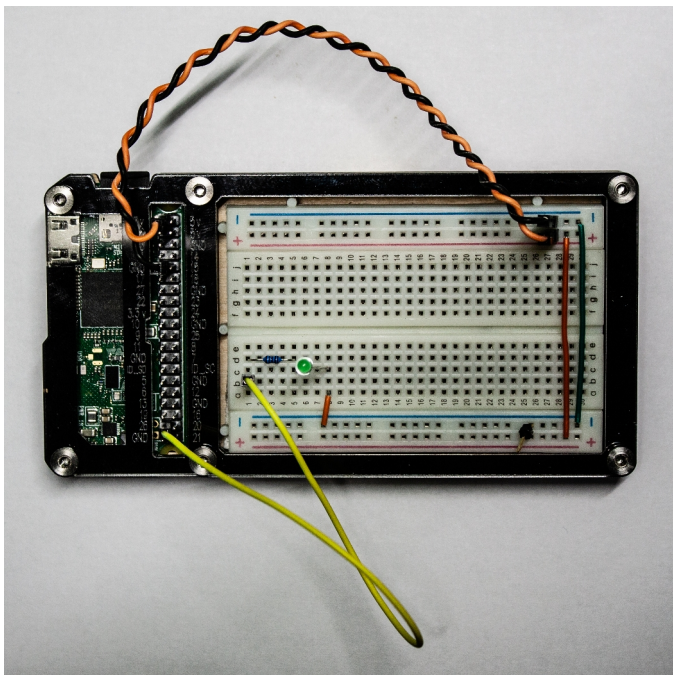

The test platform for the purposes of this application note consists of a [Raspberry Pi Zero 2 Wireless](#) mounted in a [Zebra Zero Plus Breadboard](#) case. The orange and black jumper wires connect +3.3V and GND on the Raspberry Pi expansion header to the breadboard power rails. The yellow jumper connects GPIO26 to a 1K ohm current limiting resistor and an LED.

Test Program Source Code

Available for download at: <https://repo.munts.com/muntsos/doc/blink/blink.adb>

```
WITH Ada.Text_IO; USE Ada.Text_IO;

WITH GPIO.libsimpleio;
WITH RaspberryPi;

PROCEDURE blinky IS

    LED : GPIO.Pin;

BEGIN
    New_Line;
    Put_Line("MuntsOS Ada LED Test");
    New_Line;

    -- Configure a GPIO output to drive an LED

    LED := GPIO.libsimpleio.Create(RaspberryPi.GPIO26, GPIO.Output);

    -- Flash the LED forever (until killed)

    Put_Line("Press CONTROL-C to exit");
    New_Line;

    LOOP
        LED.Put(NOT LED.Get);
        DELAY 0.5;
    END LOOP;
END blinky;
```

Exercise

This example exercise demonstrates how to create an Alire Ada program project for **MuntsOS Embedded Linux**, compile it, and run it on the test platform hardware.

Step 1: Prepare the `blinky` project directory:

```
alr -n init --bin blinky
cd blinky
alr -n with muntsos_aarch64
wget -O src/blinky.adb https://repo.munts.com/muntsos/doc/.blinky/blinky.adb
ALIRE_DISABLESTYLECHECKS=yes alr action -r post-fetch
```

The above commands will:

- Create and initialize an Alire project directory.
- Add a reference to the `muntsos_aarch64` library crate to the project.
- Download the source program `blinky.adb`.
- Run the `muntsos_aarch64` library crate postfetch script.

The postfetch script performs the following actions:

- Converts the project into a cross-compiled application for **MuntsOS Embedded Linux** running on a 64-bit AArch64 target computer, which the Raspberry Pi Zero 2 Wireless is.
- Disables GNAT style checks in `blinky.gpr` if the `ALIRE_DISABLESTYLECHECKS` environment variable is set to `yes`. This is optional, but without it, the compiler may emit style warnings when you build the project.

Step 2: Build the `blinky` project:

```
alr build
```

Step 3: Copy `blinky` to the test platform:

```
scp bin/blinky root@snoopy:.
```

Step 4: Run the test program on the test platform:

```
ssh root@snoopy
./blinky
```

The LED should begin flashing once a second, until you press `CONTROL-C`.